

MDF20-15-12 HD

Direct Drive 380V Automation for Sprung Roller Shutters

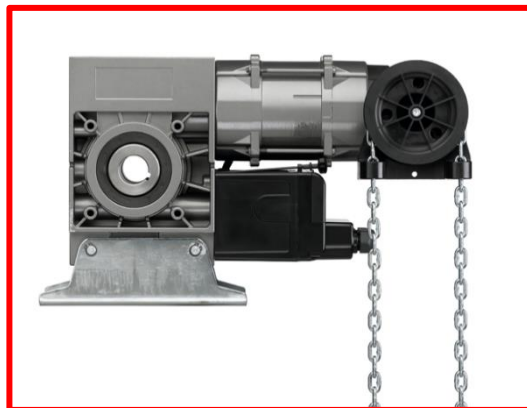
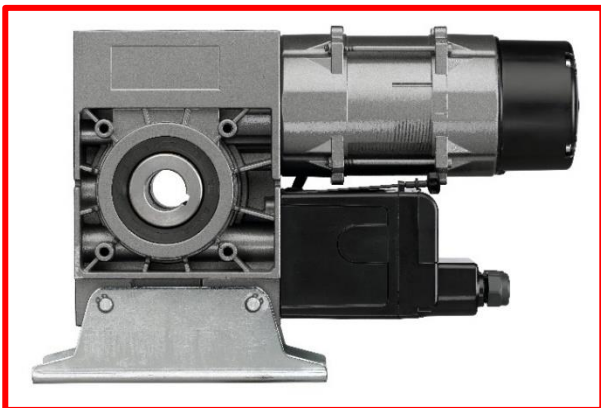

DIRECT DRIVE
Quality High Use
100% Duty Cycle Automation
For Spring Balanced Roller Shutters

FEATURES

- High Use (HD)
- Integrated Limit Switches
- Crank or Chain Manual Override Options
- Integrated Safety Catch
- Robust, Strong & Durable
- Wide Range of Control Options
- 3 Phase 380V
- Thermal Overload Protection
- Higher Torque Models available ie: 2000

SPECIFICATIONS

VOLTAGE	380V AC @ 50 Hz (Three Phase)
CURRENT INPUT	1.8 A
TORQUE	150 Nm
MOTOR OUTPUT	0.55 kW
SPEED	12 Rpm
DUTY CYCLE	80% > 30 operations / Hr (Dependent on door size)
SHAFT DIAMETER	30 mm (8mm keyway)
PROTECTION	IP54
DIMENSIONS	438 x 136 x 317 mm
WEIGHT	19 Kg

(The Company reserves the right to amend product specifications and information without notice.)

PLEASE CONTACT OUR SALES TEAM for further information.

PART OF THE MARANTEC COMPANY GROUP - OPENING DOORS IN SOUTHERN AFRICA

PROUD SUPPORTERS AND SUPPLIERS OF:

