

USER MANUAL

Part No: EDCON05002F

KT 500 PFI Controller

Rev: Dec 2025

DESCRIPTION:

The KT500 PFI was intended as an add on, "Plug & Play" solution for the Econo 600 or Econo 800 Series of roller shutter door operator. Suitable for both 230V 1ph and 400V 3phase models.

www.dortech.co.za

This KT500 controller system will replace the basic Econo Drive remote system, to offer expanded capabilities.

The KT500 PFI offers the facility for use of the following devices:

- External radio receiver (24VDC)
- Wired key switch
- Wired Push button station
- Wired infrared photocell (24VDC)

Functions:

- Impulse command
- Direction commands (Open/Stop/Close)
- Photocell input (N/C)
- Adjustable responses for safety device activation
- Courtesy light Relay (230V)

NOTE:

This controller does not offer the Auto-close function.



SAFETY:

This system should only be installed by personnel who are suitably trained and certified to work on:

- industrial roller shutter doors
- high voltage electrical equipment
- electronic equipment for gates and garage doors.

The manufacturer accepts no liability for any damages or losses, arising from use this equipment outside of its design purpose, beyond technical specification or if used with 3rd party equipment. The use of at least 1 safety device is compulsory if wireless controls are used.

Exercise caution as this is a High voltage controller (230V AC)

The use of safety body harnesses, protection safety wear and insulated tools is essential during installation.



BEFORE YOU START:

DO NOT PLUG THE CONTROLLER ONTO THE MOTOR HARNESS !!!

- Check that the roller shutter door is without damage and free from obstruction.
- Ensure that the springs on your industrial door offer no less than **50%** assistance to balance the load of the steel curtain. (Contact your door manufacturer for instructions)
- Check that the motor mounting plate is welded correctly and securely to the door's head plate.
- Check supply voltage:

Measuring between L1, L2 & L3 voltage must be 380-400V AC.

Measuring between Neutrel and any LIVE voltage must be 220-230V AC.

Measuring between Neutrel and Earth voltage must be <1.5V AC

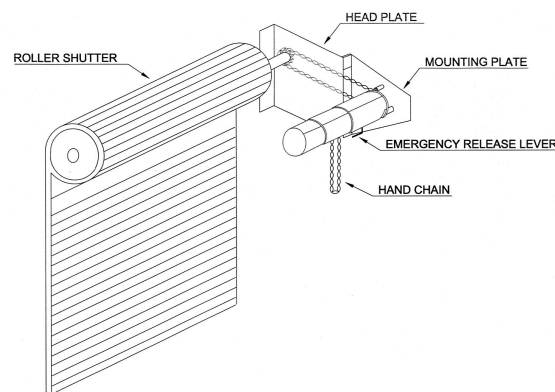

FIG.1



MOTOR SETUP:

The motors travel limits must be set first, without the KT500 Controller attached.

OPERATING MODES:

It is recommended to switch the motor to "Press & Hold" mode before attempting to set the travel limits.

By this method the user is given complete control, thus reducing the of injury or damage to any equipment.

PRESS & HOLD MODE:

Switch off the mains power. Remove the red wire from the terminal on the back of the push button station supplied. Insulate the loose red wire. This step converts the motor function to "**Dead Man**" mode. (Press & Hold).

Re-Apply Power. The motor is now operational as "Dead Mans Mode" (Press & Hold)

PRESS & RELEASE MODE:

Wire the push button station as shown in FIG 4.

FIG.2

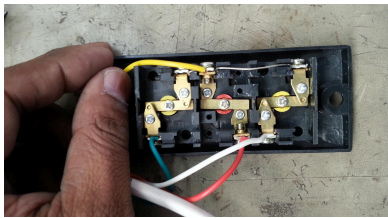
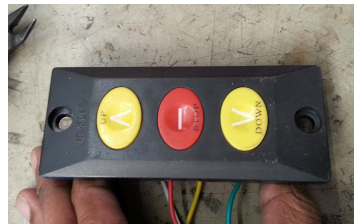
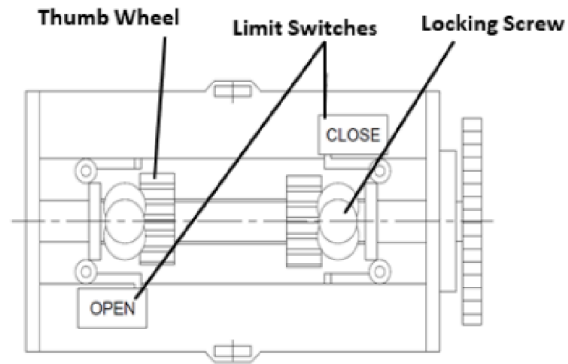

FIG.3



SETTING THE TRAVEL LIMITS:

FIG. 4

- a) Drive the door to the full **CLOSE** position by using the push button or the emergency hand chain.
- b) At the full **CLOSE** position. Loosed the Locking screw on the limit actuators. Rotate the thumb-wheel so the cam may activate the limit switch for door **CLOSE** position. Re-tighten Locking Screw.
- c) Drive the door to the full **OPEN** position by using the push button or the emergency hand chain. Rotate the thumb-wheel so the actuator may activate the **OPEN** position limit switch. Re-tighten Locking Screw.
- d) Operate the motor via the push buttons to verify if the travel limits have been set correctly. Some
- e) fine adjustment may be necessary.

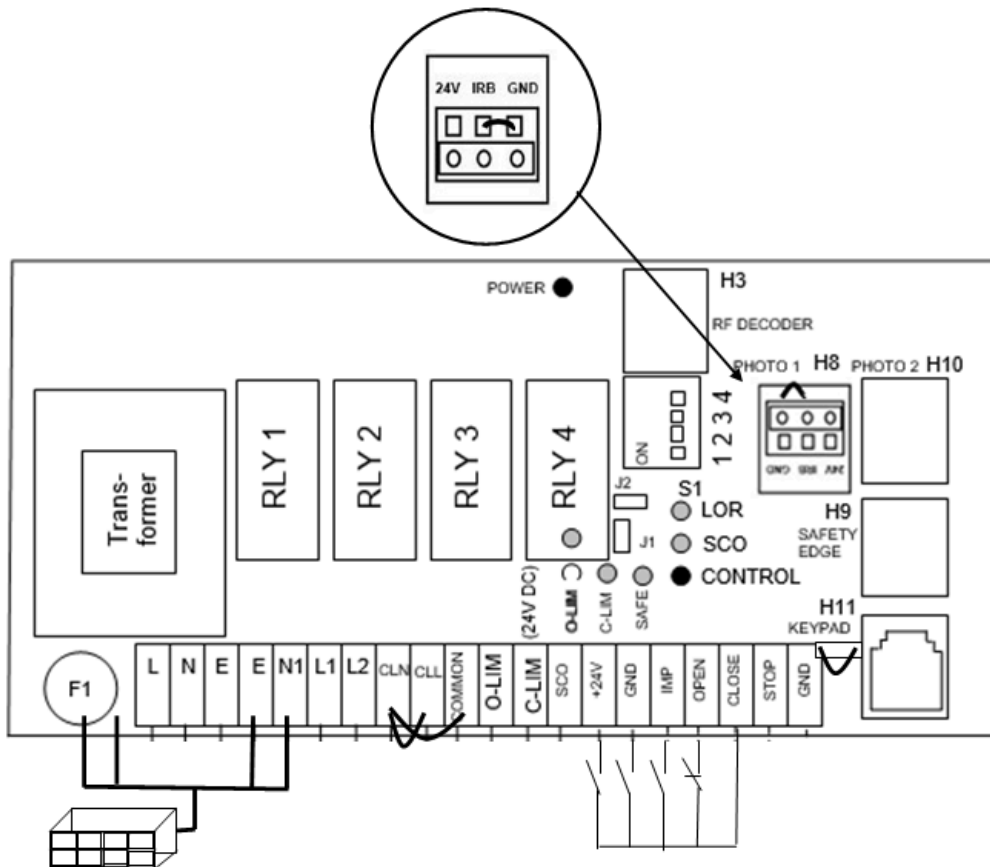

FIG.5

CONTROL HARNESS:

L - Brown
 N - Blue
 L1 - White
 L2 - yellow

COMMANDS:

Stop - N/C to GND
 GND -
 Close - N/O to GND
 Open - N/O to GND
 Impulse - N/O to GND

SAFETY:

H8 - Photocell N/C
 H11 - Marantec Pushbutton station

J1 - Limit Override
 J2 - Set Travel time

INSTALLING THE KT500



DO NOT PLUG THE CONTROLLER INTO THE MOTOR HARNESS !!!

- Step 1:** Switch mains power Off.
Step 2: Unplug the Push button station and the Econo Receiver from the motor.
Step 3: Remove the jumper link J1 & J2 from the PCB
Step 4: Bridge out the limits (Common to O-LIM & Common to C-LIM)
Step 5: Switch all PCB dipswitches **OFF**
Step 6: Wire the Push Button station onto the command terminals on the KT500 controller as shown in **FIG 6**. Then plug in the KT500 controller as shown below

PUSH BUTTON WIRING:

Open Trigger	-	Green
Close Trigger	-	White
Common	-	Yellow
Stop Command	-	Red

Step 7: Drive the door to the half open position using the emergency hand chain.

Step 8: Switch on the mains power.

Step 9: Trigger the door using the command button to verify that the door moves in the correct direction.

FIG.6

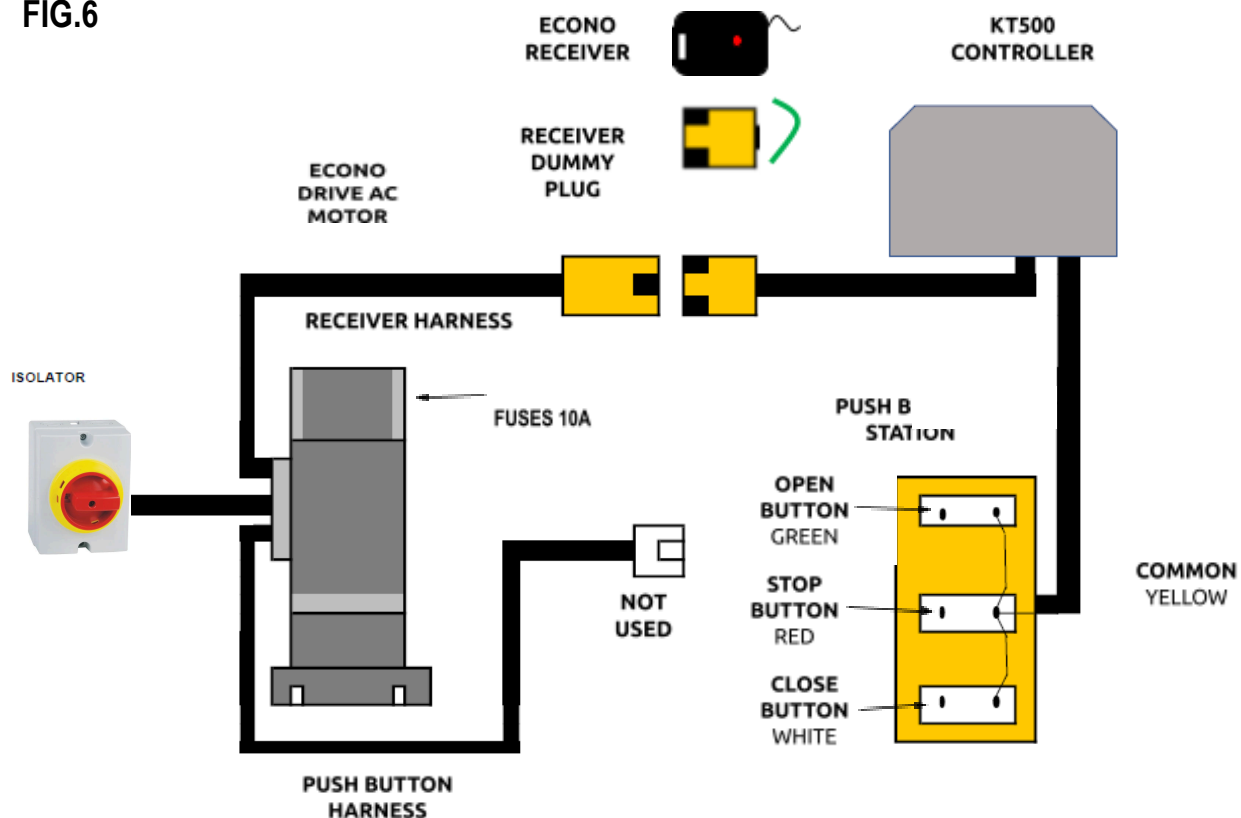

IMPORTANT:

If the relays click on the Econo 500KT controller and the motor still refuses to run, shut down power. Swap the Brown and Blue wires on the KT500 controller harness (Live and Neutral Supply lines). Now re-apply power and conduct your testing again.

Step 10: Once the motor is functioning correctly, the run time needs to be programmed .

If this step is not carried out, any installation with a photocell, will not function correctly.

SETTING THE RUNTIME

- Drive the door to the closed position using the hand chain.
- Unplug the controller from the motor loom. Fit the link on **J2** and then re-apply power to the controller. The controller is now in programming mode.
- Press and hold the Open command button to drive the door to the Open position. (the control will be in Dead mans mode- Press & hold) Release the Open button as soon as the door stops moving.
- Now press and hold the Close command button (the controller will still be in Dead mans mode) Release the button as soon as the door stops.
- Remove the link from **J2**. Disconnect the controller from the motor. Re-Apply power.
- Your run time setting is complete.

IMPORTANT:

The run time setting on the controller needs to be defaulted and then re-programmed if:

- A double trigger is necessary to get the motor to run in the opposite direction from rest.
- Activation of the stop button is necessary before the motor is allowed to run in the opposite direction.
- Obstructing the Photocell after the door has just closed, causes the door to open again.

DEFAULTING THE RUN TIME

Disconnect the controller from the motor. Apply jumper J2. Re-connect the controller to the motor. Press the stop button once. Remove the jumper J2. Disconnect the controller from the motor and then re-connect again. The run time setting has now been defaulted.

To check if the travel time setting has been done correctly:

Trigger the door to reach its closed position. Once closed walk through your Photocell if one has been fitted or alternatively remove the Rj12 bridge from the port marked Photo 1. The door must not respond.

If the door responds, then the run time needs to be defaulted and reprogrammed again.

SAFETY PHOTOCELL SETTINGS



Dip switch settings 2 and 3 enable a number of safety options when the safety devices are interrupted.



- With dip switches **2 OFF** and **3 OFF**:

If any of the safety devices are interrupted while the door is travelling in the down direction, the door will stop automatically do a long reverse and then stop at the position.

If there is a risk of dragging or lifting this option should not be used.

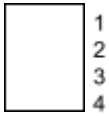

With dip switches **2 ON** and **3 OFF**:

If any of the safety devices are interrupted while the door is travelling in the down direction, the door will stop and automatically do a short reverse. The next impulse will open the door.

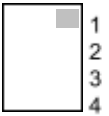

With dip switches **2 OFF** and **3 ON**:

If any of the safety devices are interrupted while the door is travelling in the down direction, the door will automatically stop – no reverse. The next impulse will open the door.

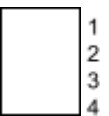

With dip switches **2 ON** and **3 ON**:

If any of the safety devices are interrupted while the door is travelling in the down direction, the door will stop and automatically do a long reverse and then stop at the open position.

If there is a risk of dragging or lifting this option should not be used.

COURTESY LIGHT SETTINGS



Dip switch settings 1 and 4 enable a number of courtesy light options, where the courtesy light comes on prior to the door moving, during door movement or after the door has stopped.

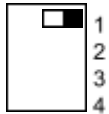

With dip switches **1 OFF** and **4 OFF**:

The courtesy light will be on while the door is in motion.



With dip switches **1 ON** and **4 OFF**:

The courtesy light is on for the duration that the door is in motion and remains on for a further 45 seconds once the door has stopped.

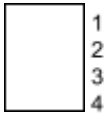

With dip switches **1 OFF** and **4 ON**:

The courtesy light comes on for 2 seconds prior to door movement and then remains on for the duration of door movement.

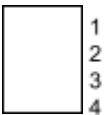

● With dip switches **1 ON** and **4 ON**:

The courtesy light comes on for 2 seconds prior to door movement and then stays on for the duration of the door movement. The courtesy light will also remain on for 45 seconds after the door has stopped.

NOTE:

After changing any dip switch settings it is necessary to remove power from the KT500 controller and then re-apply the power for the change to be effective.

TROUBLESHOOTING:

--	--

<p>Econo Motor does not run (No KT500 Controller is connected)</p>	 <ul style="list-style-type: none"> - Check that the isolator drive technology - Check the Internal 10A fuse on the motor. - Check that the Receiver Dummy Plug is fitted. - Check condition of all mains cabling and motor cabling for damages.
<p>Power switch trips when voltage is switched on. (NO KT500 controller is connected)</p>	<ul style="list-style-type: none"> - Check motor wiring to mains power. - Check for damaged push button cable. - The motor relays may be damaged
<p>Motor does not run when push button is activated. Controller only clicks. (WITH KT500 Controller connected)</p>	<ul style="list-style-type: none"> - Unplug Push button station from the white motor cable. - Swap position of brown (L) and blue (N) cables on the KT500 controller harness.
<p>The motor runs but stop before reaching the travel limit (WITH KT500 CONTROLLER CONNECTED)</p>	<ul style="list-style-type: none"> - The run time needs to be reprogrammed on the KT500 controller.
<p>The motor does not respond to any commands. (WITH KT500 CONTROLLER CONNECTED)</p>	<ul style="list-style-type: none"> - Ensure the white cable is empty - Check that all safety accessory terminals are wired as normally or have a bridge in place. - Photocell H8, H11 and STOP.
<p>The motor runs in press & hold mode only (WITH KT500 CONTROLLER CONNECTED)</p>	<ul style="list-style-type: none"> - Check that the Push button station is wired only to the KT500 controller. - Check if the J2 jumper has been removed.
<p>The remote button has to be activated more than 1 time to operate the motor (WITH KT500 CONTROLLER CONNECTED)</p>	<ul style="list-style-type: none"> - The run time needs to be reprogrammed on the KT500 controller.
<p>The photocell stops the door in the open direction only (WITH KT500 CONTROLLER CONNECTED)</p>	<ul style="list-style-type: none"> - Motor direction incorrect. Swap the cable cores on L1 and L2 terminal (white and yellow)

Technical Specification:

Type of current	AC 50 Hz
Rated voltage UN	230V +/-10%
Rated insulation voltage Ui	250V
Control voltage	24V DC
Motor output	500 Watts SINGLE PHASE
Rated current IN	5A
Mains fuse (F1)	6.3A slow-blow fuse
Overload protection for transformer	MOV
Resistance against short circuit ICW	< 10 Ka
Encapsulation class	IP44 (Internal use)
Dimensions	147mm x 110mm x 52mm
Mass	0.5 Kg
Temperature range	-20°C to +70°C

**SALES & CUSTOMER SUPPORT:
MARANTEC SA.**

DURBAN
16-18 Monte Carlo Road
Mahogany Ridge
Westmead

Tel: +27 31 700 8260
Tel: +27 31 700 8261
Email: sales@dortech.co.za

GAUTENG
Unit 1, Allandale Business Park
Cnr Le Roux & Morkel Close
Halfway House, Midrand.

Tel: +27 11 205 0082
Mobile: +27 71 877 4334
Email: salesjhb@dortech.co.za