

Drive Solutions for Commercial Doors

The perfect solution
for every requirement



Door System Information

Spring-balanced sectional doors

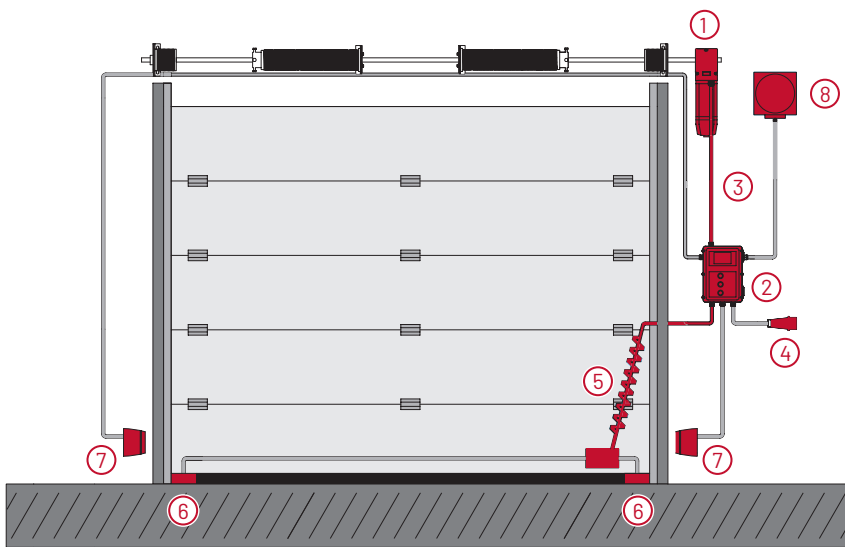

Drive with external control

- 1 Drive
- 2 Control
- 3 Wiring harness
- 4 CEE or Schuko plug
- 5 Spiral cable with junction box
- 6 Optosensor, e.g. Type F (OSE)
- 7 Light barrier, e.g. Special 630
- 8 Traffic light or signal light

Roller shutters

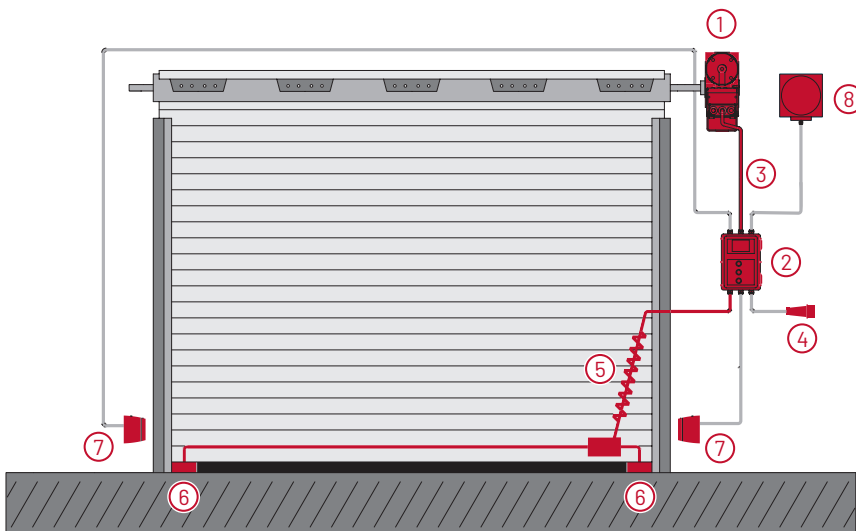

Drive with external control

- 1 Drive
- 2 Control
- 3 Wiring harness
- 4 CEE or Schuko plug
- 5 Spiral cable with junction box
- 6 Optosensor, e.g. Type F (OSE)
- 7 Light barrier, e.g. Special 630
- 8 Traffic light or signal light

Product Key Information

How to read the product name

Product name

STA	3-PH drive
STAC	3-PH drive (integr. controller)
STAW	1-PH drive
STAWC	1-PH drive (intgd controller)
SDO	1/3-PH drive

MDF	3-PH drive
KD	3-PH drive
MTZ-S	3-PH drive
MTZ-FU	1/3-PH drive

Torque index

The torque index multiplied by the factor 10 results in the output torque (Nm), for example: 10 x 10 = 100 Nm

Type of emergency operation

KU	Emergency hand crank
KE	Emergency hand chain
E	Quick release
E/KE	Emergency hand chain with maintenance release
E-FR	Release with spring return

Motor voltage

STA 1-10-24 KE 400V/3PH HD

Gear size index

Nominal speed (at 50 Hz)

The speed (min-1) at which the gearbox hollow shaft rotates

Additional information

HD	Higher duty cycle available
25,4	Standard hollow shaft
VZ	Splined hollow shaft
IP65	Protection class
AWG	Absolute encoder
MEC	Mechanical limit switch

Spring-Balanced Sectional Doors

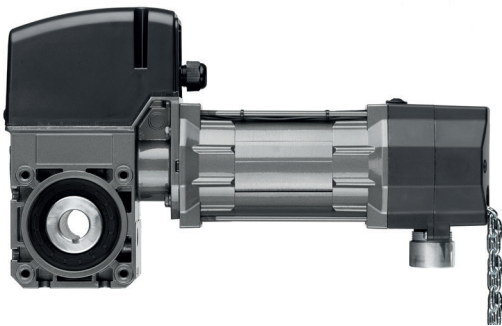

STA with external control

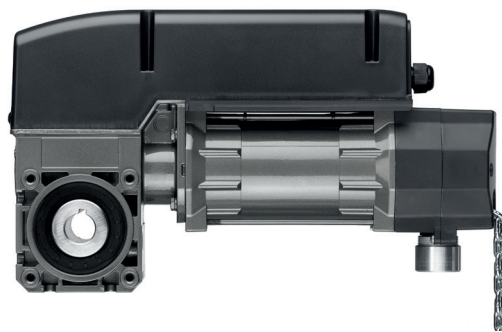

STAC with integrated control

STA/STAC

Are you looking for the perfect drive solution for spring-balanced sectional doors? Then our STA drives with integrated or external controls are the right choice for you! STA drives have a gear unit developed for this purpose with a special motor that provides a lot of power in a very small space.

STA – the convenient complete solution

With its external control, the STA is a convenient complete solution. The control ensures effortless programming from the operator level, which is possible via a plain text display, and offers numerous additional functions for all-round use.

STAC – the inexpensive alternative

With its integrated control unit and a pluggable triple button for controlling the gate, the STAC offers an inexpensive, compact alternative. It is ideal for convenient daily use.

Drive features and benefits

- Housing made of die-cast aluminum
- Standard hollow shaft 25.4 mm; special 31.75mm, 35mm, and hex 32mm solutions are also available
- Rolled worm shaft
- Higher duty cycle available
- Static holding torque of 600 Nm of the STA gearbox – nothing can fall if a load-bearing element breaks/is defective
- Various emergency controls available – reliable operation in the event of a power failure

- End-position switch-off with electronic end-position system or mechanical limit switches
- Accessories from other providers can also easily be connected
- Four different mounting types for STA: direct attachment, axle chain drive, flange, or rail-guided assembly
- All voltages/frequencies up to 480 V/3~ available on request
- IP65

Our flexible
long-running
favorite for
sectional doors

STA Drive Mounting Types

Direct assembly

The drive is attached directly to the spring shaft of the sectional door. A torque support is used to attach the drive to the wall or the shutter frame.

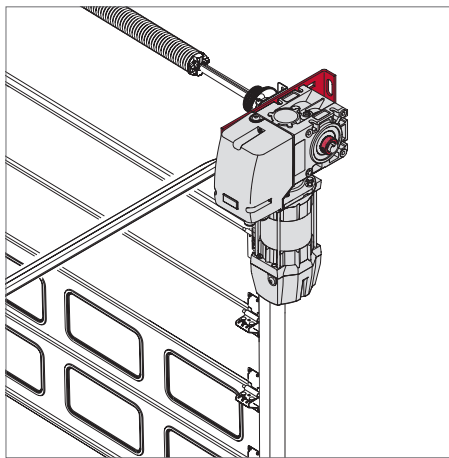

Axle chain drive

The drive is attached to the spring shaft of the sectional door via an axle chain drive. With a spring shaft flange width of just 62 mm, this variant is suitable if there is not enough space for push-on mounting.

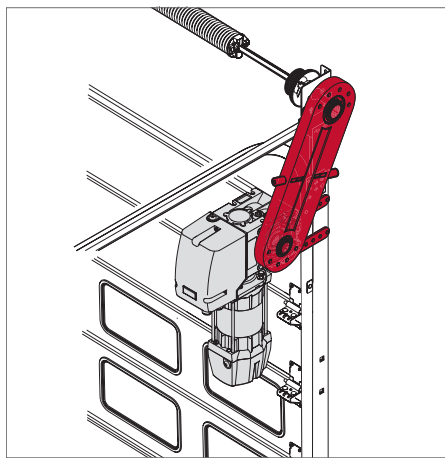

Mounting with flange

The drive is attached to the spring shaft with a plug-in shaft adapter. This is an ideal solution, especially for the 40 mm spring shaft. A torque support is used to attach the drive to the wall or the door frame.

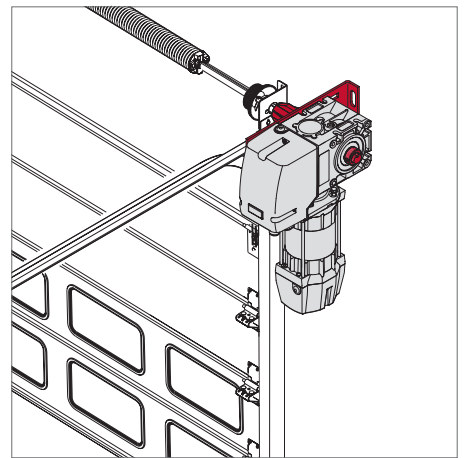

STA Mounting Types

Rail-guided assembly only for STAI

When drives are mounted on rails, the drive is attached to a drive rail (4) using the supplied STAI mounting bracket. The drive rail is attached under the building ceiling using a STAI suspension set for the drive rail (2) and for the drive (1). An STAI installation bracket (3) (part of the suspension set) is attached to the door leaf.

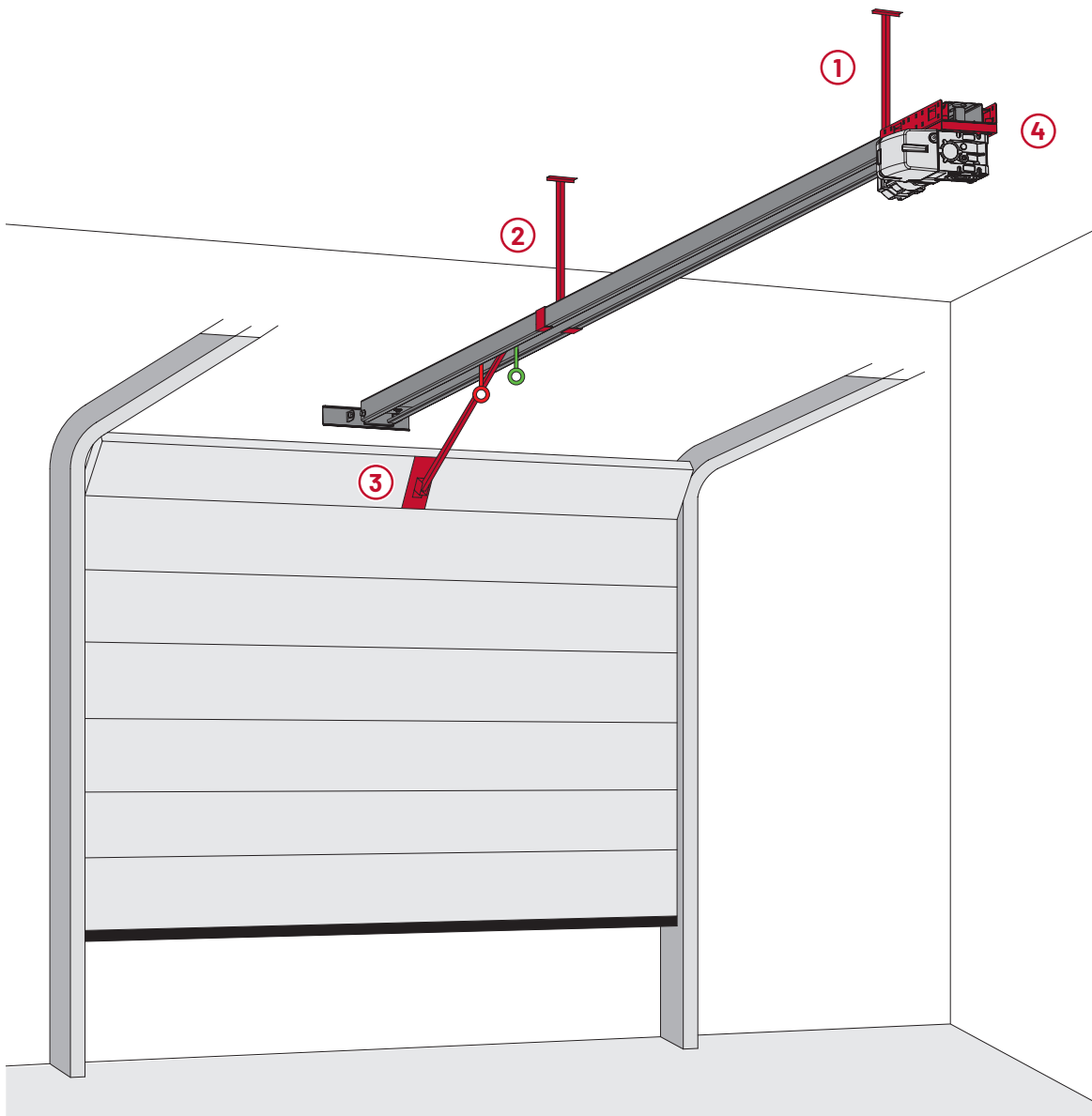

Technical Data

A selection from our product portfolio

	Output torque	Nominal speed	Operating voltage	Motor performance	Hollow shaft	Emergency operation	Door weight	Door size
	Nm at 50 Hz	min-1 at 50 Hz	V	kW	mm		max. kg	m ²
STA 1-5-24	50	24	400/3~	0.25	25.4	E KE KU	234	18
STA/STAC 1-10-24	100	24	400/3~	0.37	25.4	E KE KU	390	30
STA/STAC 1-11-19	110	19	400/3~	0.37	25.4	E KE KU	390	30
STA/STAC 1-13-15	130	15	400/3~	0.55	25.4	E KE KU	585	45
STA/STAC 1-10-30	100	30	400/3~	0.55	25.4	E KE KU	585	45
STA/STAC 1-11-24	110	24	400/3~	0.55	25.4	E KE KU	585	45
STA/STAC 1-12-19	120	19	400/3~	0.55	25.4	E KE KU	585	45
STA/STAC 1-14-19	140	19	400/3~	0.65	25.4	E KE KU	650	50
STA/STAC 1-10-30 HD	100	30	400/3~	0.55	25.4	E KE KU	650	50
STA/STAC 1-11-24 HD	110	24	400/3~	0.55	25.4	E KE KU	650	50
STA/STAC 1-12-19 HD	120	19	400/3~	0.55	25.4	E KE KU	650	50
STA/STAC 1-13-15 HD	130	15	400/3~	0.55	25.4	E KE KU	650	50
STA 1-10-30 FU/I	100	30	230/1~	0.55	25.4	E KE KU	585	45
STA 1-11-24 FU/I	110	24	230/1~	0.55	25.4	E KE KU	585	45
STA 1-12-19 FU/I	120	19	230/1~	0.55	25.4	E KE KU	585	45
STAI 1-10-30 FU/I	100	30	230/1~	0.55	25.4	-	390	30
STAW/STAWC 1-6-24	60	24	230/1~	0.37	25.4	E KE KU	260	20
STAW/STAWC 1-7-19	70	19	230/1~	0.37	25.4	E KE KU	260	20

External and Integrated Controls

CS 320 – External Control



The convenient control for complex requirements

Do you need a control for roller, sectional, or PVC high-speed doors? CS-320 controls are optimally matched to the requirements of these types of use and will convince you! The fully equipped microprocessor controls can be used with an absolute encoder as well as with a mechanical limit switch.

With numerous connection and expansion options, even complex control tasks are child's play for the CS 320. It is suitable for new installations, but also for safely upgrading existing gate systems.

Features and benefits

- Based on the proven concept of the CS 310
- Certified according to DIN EN 12453:2017
- Integrated safety input, in accordance with the increased requirements for safety-related parts (PLC, Cat.2)
- New safety components on 8.2 kΩ basis for crosscircuit monitoring (PLC, Cat.2) available: slack rope switches, monitoring switch for safety catch devices, pass door sensors
- Internal fuse protection at the mains input (3-phase), for optimum adaptation to the drive system
- Operating modes: dead man, self-holding with optional accessories
- Programming using three-button navigation on an LC display with plain text output in German, English, French, Spanish, Dutch, Danish, Polish, Czech, Italian, Finnish, Swedish, Turkish, Norwegian, and Hungarian
- Convenient programming of the electronic end-position system on the control unit itself
- Terminals for connecting command devices and safety devices
- Four programmable relay outputs and two programmable inputs
- Integrated MS-Bus interface for connecting expansion modules
- Integrated fuse for second disconnection device as standard
- Powerful energy supply for external devices (24 V DC/500 mA)
- Integrated error log
- Terminal for 230 V power supply for external elements, protected with a 1A microfuse at 400 V/3~
- A frequency converter motor and the expansion modules are automatically recognized by the control
- Due to the flexibility in the control housing technology, extensive control sequences can also be implemented, e.g. for roller grilles with pull-in protection and two-way traffic control (red/green for entry/exit)



Programming display

CS 265 – Integrated Control

The compact control for sectional doors

The CS 265 is a compact basic control that is also equipped with many connection and setting options. Safety features such as a light barrier or a closing edge safety device can be easily connected using the provided terminals.

The CS 265 is integrated directly into the drive motor, but can optionally also be built into an external housing. The CS 265 works on the basis of an absolute encoder or with mechanical limit switches.

Simple programming

The programming of the end positions and basic functions is carried out via the intelligent CS-I-15 button from the operator level. Additional function settings can be configured with the LC display with plain text display via the MS-Bus interface (optional).

Features and benefits

- Operating modes: dead man, impulse operation "open," impulse operation "closed," and automatic operation with optional accessories
- Proven integrated control unit for standard applications with digital or mechanical limit switches
- Terminals for connecting command devices and safety devices

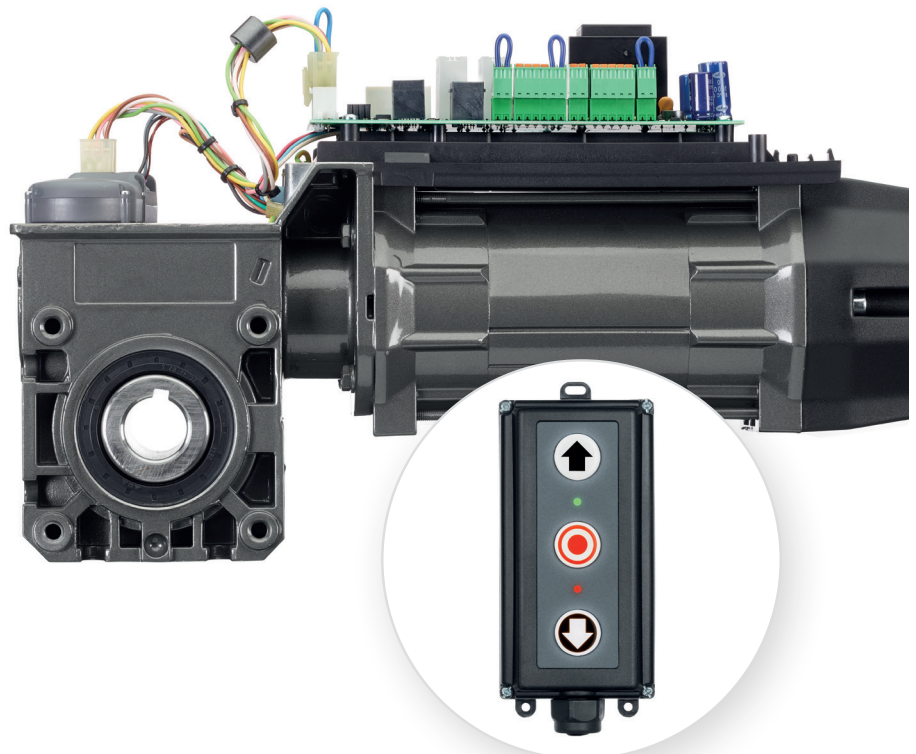

CS-I-15 Button

The right control for every requirement

Whichever type of control you need, whether it's for a roller shutter or sectional or high-speed door: There is something for every application in our product portfolio! Our assortment ranges from relay controls to underground parking garage controls with traffic light functions to complex gate controls with integrated frequency converters or controls for loading bridges.

Do you need additional information? In our specialist catalogs you can find

additional special controls for use on sliding doors, fire doors, or in explosion-proof rooms. Just get in touch with your contact person!

CS
Controls for industrial doors

RS
Controls for dock leveler



VTA

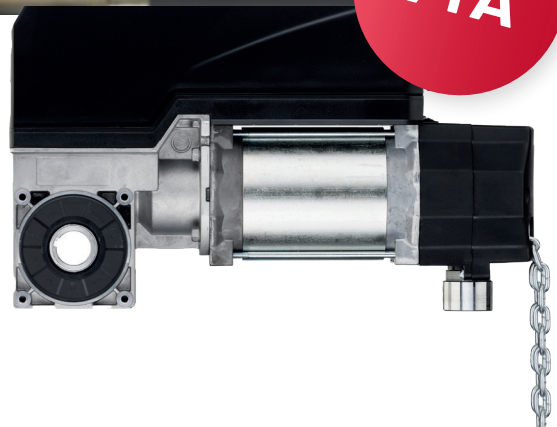

VTA 14-61

Our commercial door drive with direct current technology

Discover our VTA – the first model of a new generation of high-quality commercial door drives with direct current. The sectional door drive with DC motor guarantees a high level of safety through power cut-off and high-quality components that make the product durable. Thanks to its DC technology, you can easily commission it anywhere in the world.

The VTA can be easily and inexpensively equipped with a battery back-up. In an emergency, the drive can be operated via a chain, a crank, or an unlocking device. This guarantees operational safety at all times. In addition, the drive system is compact, visually appealing, and easy to install. The drive has an integrated control that can operate most applications.

Features and benefits

- No active closing edge safety device required for doors up to 14 m²
- Force limitation in the “open” and “closed” directions
- Soft Start and Soft Stop protect the door and reduce repair costs without the use of frequency converters
- Intelligent running enables movement with high closing speed beyond the standard measuring height
- Easy parameterization of variable speeds
- Integrated digital limit switches
- Temperature range from -20 °C to +40 °C
- Static holding torque of 400 Nm of the STA04 gearbox – nothing can fall down if a load-bearing door element breaks/is defective.
- IP54

VTA for all cases

In addition to the VTA 14-61 we supply even more powerful models based on our STA01 gear units and extending the range of applications for sectional door operators with DC motor technology. Whether for larger and heavy doors, with double running speed or rail-guided installations: We always have the right DC drive solution for you.



Sectional Door Drives with Direct Current

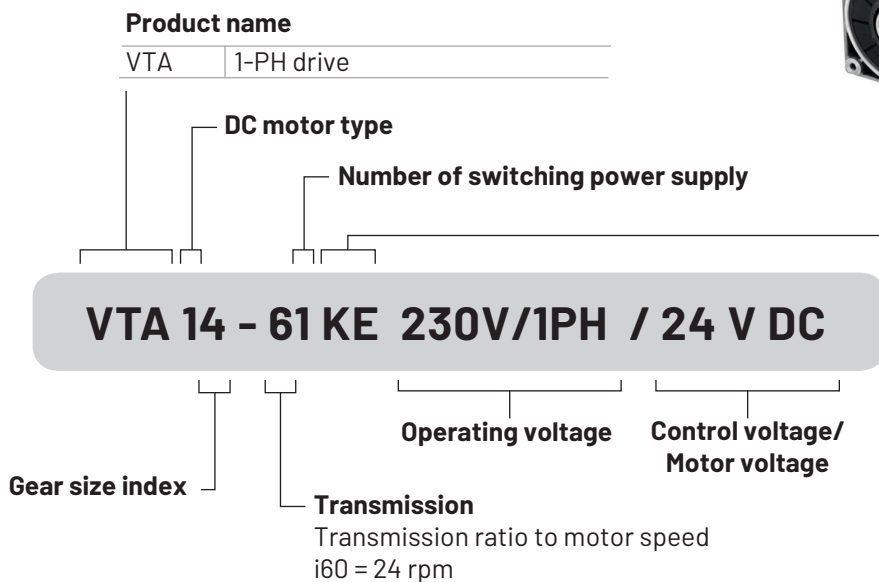
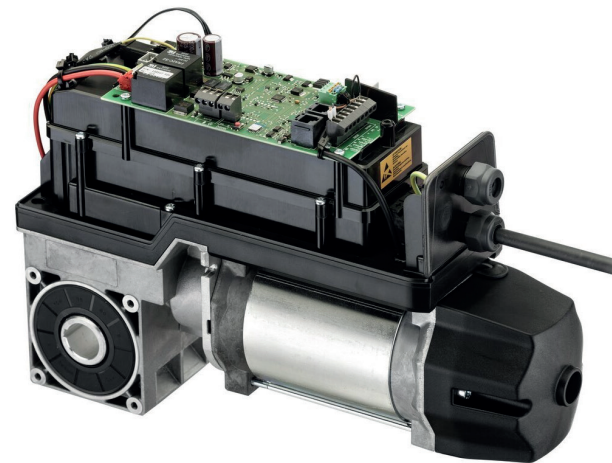

Type of emergency operation

KU	Emergency hand crank
KE	Emergency hand chain
E	Quick release
E/KE	Emergency hand chain with maintenance rele
E/KU	Emergency hand crank with maintenance rele

	Drive torque	Nominal speed	Operating voltage	Voltage control	Motor performance	Hollow shaft	Emergency operation	Door weight	Door size
	Nm at 50 Hz	min-1 at 50 Hz	V	V DC	kW	mm		max. kg	m ²
VTA 14-61	25	24	100-240	24	0.16	25.4	E KE KU	234	18
VTA 11-32	20	45	100-240	24	0,22	25,4	E KE KU E-KE E-KU	234	18
VTA 11-62	35	24	100-240	24	0,25	25,4*	E KE KU E-KE E-KU	325	25
VTA 11-72	45	19	100-240	24	0,28	25,4*	E KE KU E-KE E-KU	364	28
VTAI 11-32	20	45	100-240	24	0,25	25,4	E KE KU E-KE E-KU	234	18

*Other hollow shaft on request

Drives for Roller Shutters and Roller Grilles

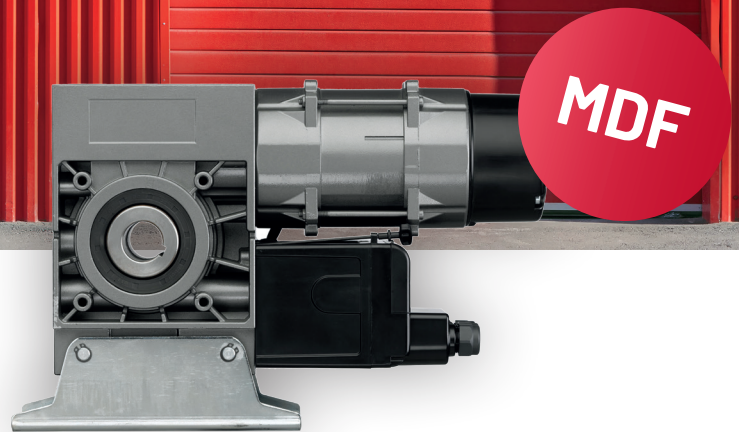

MDF

The safest solution for roller shutters

Do you have a roller shutter or roller grille and need a safe solution with a safety catch? Then you should get to know our MDF direct-mount drives! A maintenance-free and TÜV-tested safety catch is already integrated in these drives, which offers the best and safest solution for roller shutters: No roller shutter curtain can fall if the connection between worm wheel and worm shaft in the gear box is interrupted due to gear wear. This way you don't have to take any additional mechanical safety precautions!

Compact design

In addition to the safety aspect, our MDF drives also feature an excellent compact design, which enables

different installation variants and convenient assembly. With a complete series from 100 to 2,000 Nm, with and even up to 4,000 N with synchronous assembly, we offer the right solution for every situation on site!

Features and benefits

- Integrated and TÜV-tested safety gear with integrated damping
- Safety gear operates independently of position and speed and is also both maintenance-free and wear-free
- Rolled worm shaft – high-quality materials in the gearbox, very good self-locking values
- MDF drives are equipped with a thermocouple in the motor winding; this prevents overloading due to overheating

- Higher duty cycle available
- Various emergency controls available – reliable operation in the event of a power failure
- End-position switch-off with electronic end-position system (AWG) or mechanical limit switches (MEC)
- 20 or 30 cycles (HD) per hour
- All cable connections between the MDF gear motor and the control unit are pluggable
- Operation with frequency converter possible
- Temperature range from $-20\text{ }^{\circ}\text{C}$ to $+60\text{ }^{\circ}\text{C}$
- IP54

High-Speed Drives Roller Shutter

MTZ-S/MTZ-FU

When time is of the essence

Would you like to automate high-speed doors so that your operational processes aren't disrupted? The MTZ drive series offers the optimal solution for this application and is suitable for high-speed roller shutters, as well as light and heavy PVC doors. A maintenance-free safety gear is already integrated into MTZ drives, thus offering

the safest variant for your door. The MTZ-FU is available for operation with a frequency converter.

Features and benefits

- Various gear/motor combinations offer a power range from 40 Nm to 440 Nm and a speed of 45 rpm to 180 rpm at 50 Hz
- All gear/motor combinations contain a safety gear system with integrated damping
- The safety gear operates inde-

pendently of position and speed and is also both maintenance-free and wear-free

- High holding force thanks to an additional electromagnetic brake
- The version with frequency converter is possible in an external CS housing (combo, maxi, or steel housing)



MDF Technical Data

A selection from our product portfolio

	MDF 05-14 12	MDF 20-22-12	MDF 30-27-12 HD	MDF 30-42-12	MDF 30-50-12	MDF 50-75-10	MDF 60-100-9	MDF 60-140-9 HD	MDF 70-165-8 HD	MDF 70-200-8 HD
Output torque Nm at 50 Hz	140	220	270	420	500	750	1,000	1,400	1,650	2,000
Nominal speed min-1 at 50 Hz	12	12	12	12	12	10	9	9	8	8
Operating voltage V	400/3~	400/3~	400/3~	400/3~	400/3~	400/3~	400/3~	400/3~	400/3~	400/3~
Motor power kW	0.45	0.75	0.75	1.1	1.1	1.4	1.5	2	2.2	2.5
Hollow shaft mm	30	30	40	40	50	50	50	50	55	55
Emergency operation	KE KU	KE KU	KE KU	KE KU	KE KU	KE KU	KE KU	KE KU	KE KU	KE KU

Roller shutter max. load in kg

Winding shaft diameter										
Ø 133 mm	145	227	279	434	516	774	1032	1445	1703	2065
Ø 159 mm	124	195	239	372	443	665	886	1241	1463	1773
Ø 193.7 mm	104	164	201	313	373	559	746	1044	1231	1492
Ø 219.1 mm	94	147	180	291	334	501	668	935	1102	1336
Ø 273 mm	77	120	148	230	274	410	547	766	903	1095
Ø 323.9 mm	65	103	126	196	234	351	467	654	771	935

All indicated weights take into account a safety reserve of 20 % and a slat thickness of 25 mm.

Easy drive selection

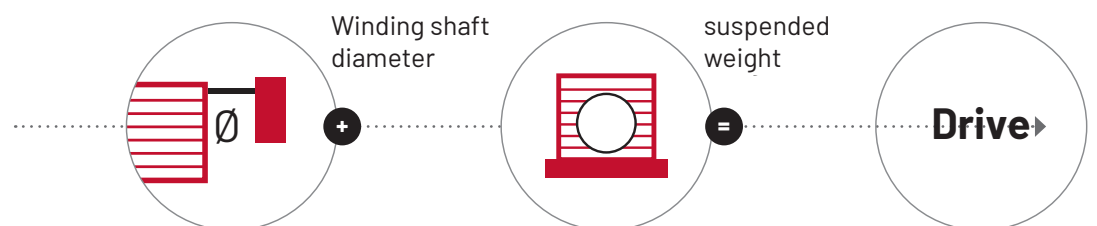

MTZ Technical Data

A selection from our product portfolio

	MTZ-S 05-4-135	MTZ-S 20-7-90	MTZ-S 30-14-90	MTZ-S 30-20-90	MTZ-FU 05-7-90	MTZ-FU 05-4-135	MTZ-FU 20-9-135	MTZ-FU 30-25-90 HD	MTZ-FU 30-15-150 HD	MTZ-FU 50-29-105 HD
Output torque Nm at 50 Hz	40	70	140	200	70	40	90	250	150	290
Nominal speed min ⁻¹ at 50 Hz	135	90	90	90	90	135	135	90	150	105
Operating voltage V	400/3~	400/3~	400/3~	400/3~	230 V/1~	230 V/1~	400/3~	400/3~	400/3~	400/3~
Motor power kW	0.55	0.75	1.5	2.2	0.75	0.75	1.5	3.0	4.0	4.4
Hollow shaft mm	25 25.4 30		25 25.4 30 40		25 25.4 30			25 25.4 30 40		50
Emergency operation	KE KU	KE KU	KE KU	KE KU	KE KU	KE KU	KE KU	KE KU	KE KU	KE KU

PVC door max. load in kg at 50 Hz (87 Hz)

Winding shaft diameter	MTZ-S 05-4-135	MTZ-S 20-7-90	MTZ-S 30-14-90	MTZ-S 30-20-90	MTZ-FU 05-7-90	MTZ-FU 05-4-135	MTZ-FU 20-9-135	MTZ-FU 30-25-90 HD	MTZ-FU 30-15-150 HD	MTZ-FU 50-29-105 HD
Ø 88.9 mm	69	120	240	343	120 (84)	69 (48)	155 (109)	429 (300)	258 (180)	567 (397)
Ø 101.6 mm	60	106	211	302	106 (74)	60 (42)	136 (95)	378 (264)	227 (159)	498 (349)
Ø 114.3 mm	54	95	190	272	95 (67)	54 (38)	122 (85)	340 (238)	204 (143)	449 (314)
Ø 133.0 mm	47	82	164	235	82 (57)	47 (33)	106 (74)	293 (205)	176 (123)	387 (270)
Ø 159 mm	40	69	138	198	69 (48)	40 (28)	89 (62)	247 (172)	148 (103)	326 (228)
Ø 193.7 mm	33	57	114	163	57 (40)	33 (23)	73 (51)	204 (142)	122 (85)	270 (189)

Roller shutter max. load in kg at 50 Hz (87 Hz)

Winding shaft diameter	MTZ-S 05-4-135	MTZ-S 20-7-90	MTZ-S 30-14-90	MTZ-S 30-20-90	MTZ-FU 05-7-90	MTZ-FU 05-4-135	MTZ-FU 20-9-135	MTZ-FU 30-25-90 HD	MTZ-FU 30-15-150 HD	MTZ-FU 50-29-105 HD
Ø 101.6 mm	51	90	180	258	90 (63)	51 (35)	116 (81)	322 (225)	193 (135)	425 (297)
Ø 114.3 mm	47	82	164	234	82 (57)	47 (33)	105 (74)	293 (205)	176 (123)	386 (270)
Ø 133.0 mm	41	72	144	206	72 (50)	41 (29)	93 (65)	258 (181)	155 (109)	341 (239)
Ø 159 mm	35	62	124	177	62 (43)	35 (25)	80 (56)	222 (155)	133 (93)	293 (205)
Ø 193.7 mm	30	52	104	149	52 (36)	30 (21)	67 (47)	186 (130)	112 (78)	246 (172)
Ø 219.1 mm	27	47	94	134	47 (33)	27 (19)	60 (42)	167 (117)	100 (70)	220 (154)

All weight information takes into account a safety reserve of 20 % and a curtain thickness of 6 mm PVC curtain or 25 mm roller shutter profile thickness.

KD – Chain Drives for Roller Shutters

For special installation situations

Special situations on site require special drives: Get to know our powerful KD series chain drives! They are particularly suitable if you have limited space or if your door is very heavy. KD drives have a special base for extremely secure installation. If a direct-mount drive for direct attachment is not possible, we can use a chain drive for you.

Features and benefits

- A complete series from 70 Nm to 1,650 Nm available
- 24 rpm for all motor types
- Sprocket ratio 2 : 1, 3 : 1, 3.8 : 1, or 4.5 : 1; the roller shutter can weigh several tons

- All KD motors have a pin for attaching a sprocket
- A console for tensioning the chain is available
- Separate fall arrest devices from the F and TS series are available for fall protection
- Many mechanical accessories such as roller chains, sprockets, weld-in shafts, and weld-in discs are available

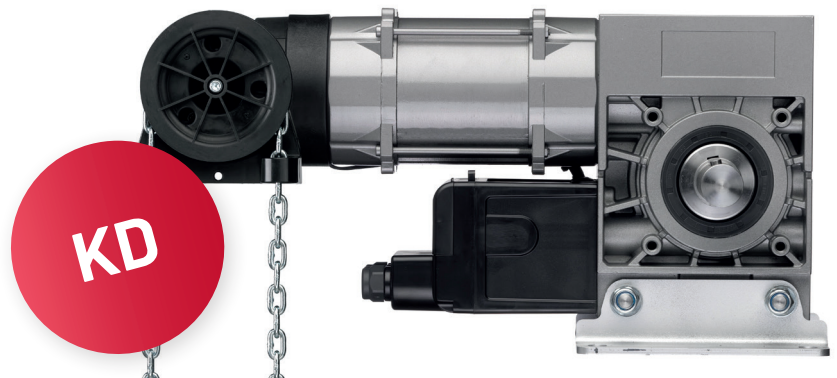

TS/F/FG Safety Gears

Important for your safety

External safety devices are generally required in connection with chain wheel drives to secure the curtain from falling. Together, the TSN-0, F1 and FG series safety gears cover all requirements on the market.

series are equipped with a slide for the operating or catch position

- All safety gears are TÜV-tested; Certificates are available
- All safety catches offer a short

fall path, integrated damping and corrosion protection as standard

- All safety catches are maintenance- and wear-free

Features and benefits

- Depending on the weight of the curtain and the diameter of the winding shaft, the two series offer the right model
- The TSN-0 and the large FG series can be reset after a catch; all other models must be replaced after fall
- The safety catches in the FG

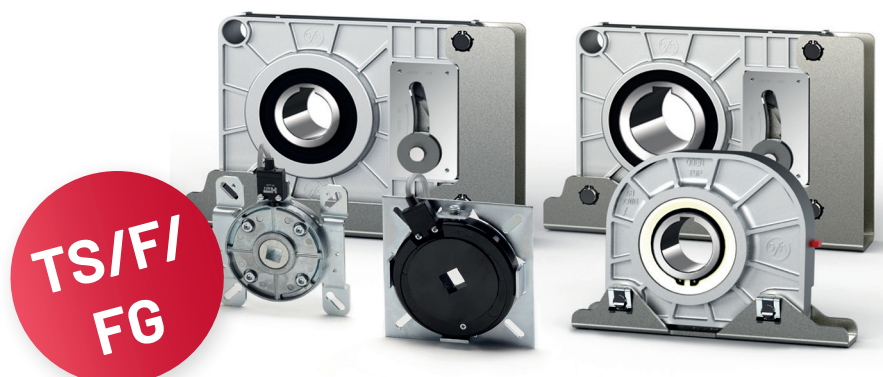

Sliding Door Drives

SDO



Drive with manual emergency release

Whether you want to retrofit an existing sliding door with a drive or automate a new sliding door: Our SDO drives are ideally suited for this!

SDO drives are particularly reliable and safe – they won't let you down, even in the event of a power failure. You can operate your sliding door manually at any time using an integrated emergency release, which is included as standard.

Features and benefits

- Pin (plug-in spigot) can be inserted on both sides (right/left output)
- Socket or flange mounting
- Product range from 80 Nm to 330 Nm and speeds from 24 rpm to 45 rpm
- The maximum door weight is 4.4 tons with an M6 rack
- With external frequency converter in the CS combo housing
- Optional stainless steel cover
- Emergency operation via powerful easy-to-use emergency release

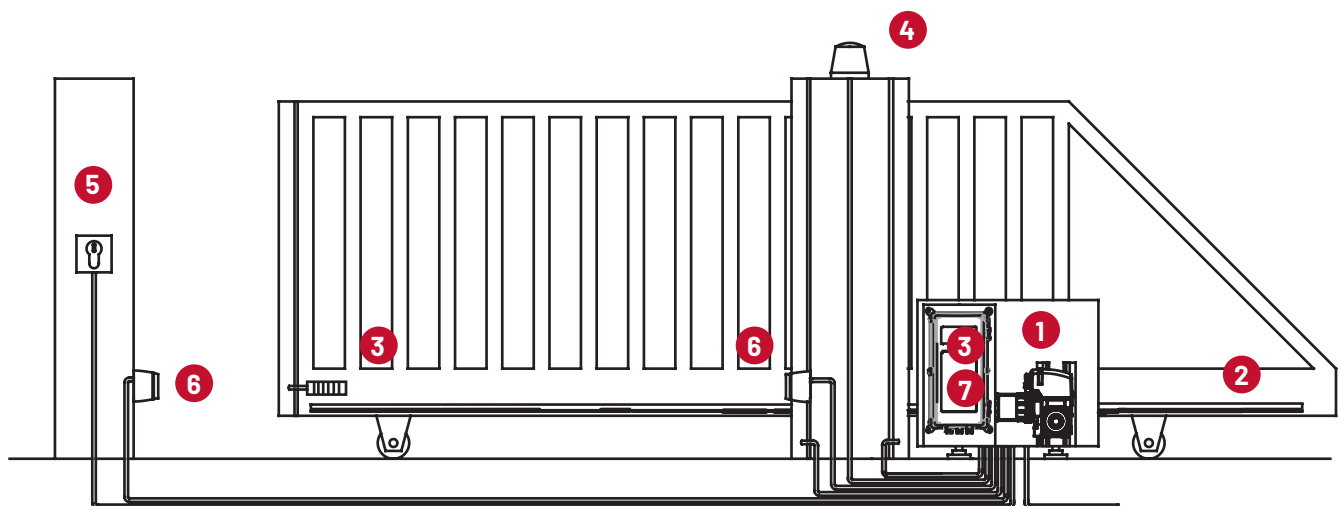

- 1 Drive with spur gear
- 2 Rack
- 3 "Radio" transmission system
- 4 Signal lamp

- 5 Key switch
- 6 Light barrier
- 7 Control unit with radio receiver, internal, 868 MHz



Special Drives

ATEX – Protective Drive System

Roller shutter drives and sectional door drives for explosion-protected areas

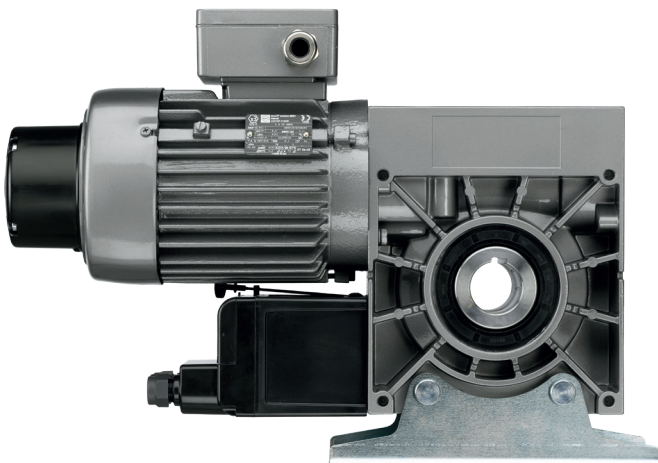

The drive models in the ATEX version of the MDF and STA series are specially designed for use in explosion-protected areas. We offer solutions for Zone 1 and Zone 2 gas processing. All drive and control components meet the requirements for safe operation in the respective zones. This also includes not using emergency hand chains. Emergency operation is therefore only possible using a crank.

There are also special controls and accessories for this application, e.g. EX main switches, EX light barriers, or EX buttons. We would be happy to send you more information on request!

MTS – Drive for Swimming Pool Covers

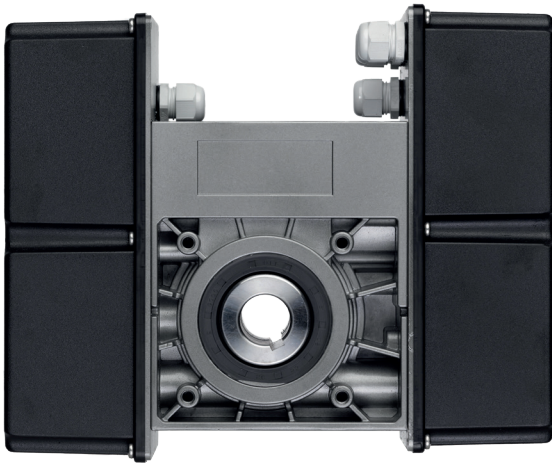

Specially developed for installation in swimming pool areas:
Find out more about our MTS series drives!

MTS drives are equipped with a built-in stainless steel hollow shaft and a 24-volt direct current motor, which offer maximum safety and are ideally suited for use in this area. The end position is set via an electronic end-position system or with the option of using mechanical limit switches.

We offer both standardized special drives for swimming pool covers and individual custom solutions – just get in touch!





What do you need? We have the right solution for **all applications!**

FDO – Folding Door Drive

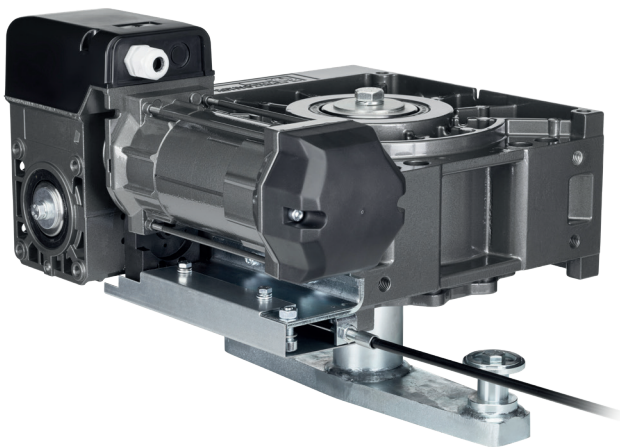

We also have the right product range for you for folding doors with our FDO drives! FDO drives feature a compact design, which enables different installation options.

A convenient emergency release with a Bowden cable is already integrated and can be controlled from the operator level with a rugged operating lever. A two-stage worm gear drive, a massive pivot lever, and a powerful electric motor were specially developed for folding doors and have been optimized for the requirements in this area.

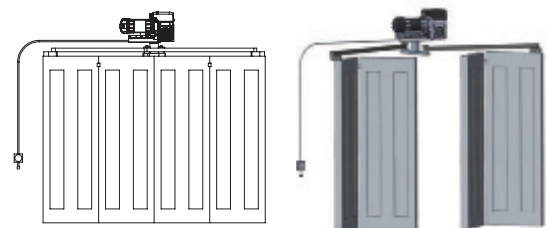

FTU – Fire Protection Drives for Fire Protection Doors

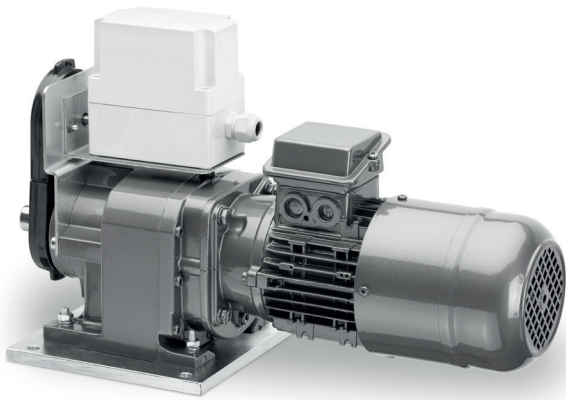

Would you like to automate a fire door? Then the chain drives of our FTU series are the right choice for you, because they were specially developed for this application!

A roller chain connects the drives with the shaft of the door. In the event of a fire, the drive closes automatically and without any energy supply. In normal operation, the power-operated door is opened and closed again by a three-phase motor. The gear mechanism consists of a non-self-locking spur gear, a centrifugal and magnetic brake, as well as an electric motor and limit switches. A magnetic brake supports the load on the door and is released immediately in the event of a fire. The centrifugal brake limits the closing speed of the door.



Drive Characteristics

Emergency operation options

- Quick release (E)
- Emergency hand chain with maintenance release (E/KE)
- Emergency hand chain (KE)
- Emergency hand crank (KU)
- Quick release with spring return for drives with central mounting (E-FR)



Emergency hand crank



Emergency hand chain

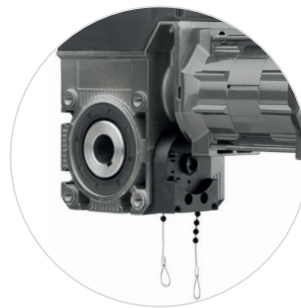

Quick release



Quick release with spring return for drives with STA installation in the middle of the door

Types of limit switches

End-position setting via electronic end-position system (AWG) or mechanical limit switches (MEC)



Electronic end position system (AWG)

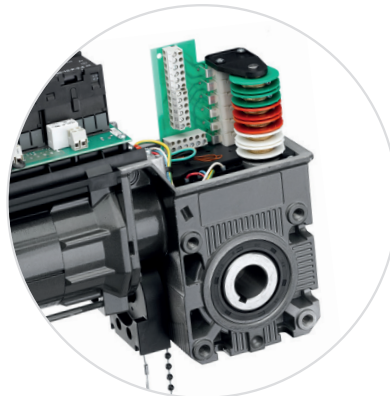

Mechanical limit switches (MEC)

Handheld Transmitter and Safety Accessories

Handheld transmitter and multi-bit radio accessories



Handheld transmitter
2- or 4-channel
digital 392, 382, 384

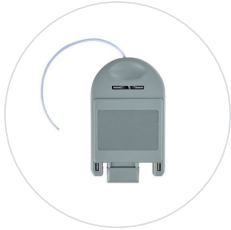

Radio antennas
Digital CS, Digital 168



Loop detector
Control 403



Sensors for Condor
contactless opening



Traffic lights

Safety accessories

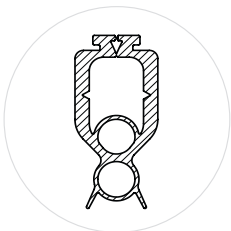

Door end profile
(2 chambers)



Coiled cable



Door leaf connection box



Type F Optosensor set



Light curtain
GridScan/Pro



Contact strips
8k2 ASO
Protect-contact

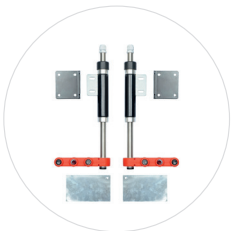

**Leading closing edge
safety device**
Protect-Opto 602/603



Light barriers
Special 633



**One-way
24 V light barrier**



**Pull-in protection
Sender/Receiver**

Mechanical accessories



Axle chain drive



Motor consoles
K-Series



**Emergency hand chain
redirection**
for STA



**Stainless steel housing for
external release**
Lock 690



Sprockets and accessories
for KD

Marantec Marienfeld GmbH & Co. KG

Remser Brook 11
33428 Marienfeld
Germany

Fon +49 5247 705-0

sales@marantec.com
www.marantec.com

Marantec Legden GmbH & Co. KG

Neue Mühle 4
48739 Legden
Germany

Fon +49 2566 9336-0

sales@marantec.com
www.marantec.com

Marantec UK

Unit 10 Christleton Court, Manor Park,
Runcorn, WA7 1ST
UK

Fon +44 1928 579 050

info@marantec.co.uk
www.marantec.co.uk

Marantec Finland (Ovitor Oy)

Sienitie 24
PL 10 - 00761 Helsinki
Finland

Fon +358 20 7106-600
Fax +358 20 7106-616

sales@marantec.com
www.marantec.com

